

# WE'VE REVOLUTIONIZED THE CORRIDOR LOCKER

Duralife Lockers are the first HDPE plastic locker that is fully fire-rated for your corridor application. Specially designed to meet the demands of the school environment, Duralife Lockers are built to withstand the harshest daily use. Scranton Products begins with the best material, American made HDPE that is engineered for strength and durability.

## FEATURES & BENEFITS

- Fire Rated, NFPA 286 compliant
- Will never rust, corrode or delaminate
- Impact and dent resistant
- Scratch resistant
- Moisture impermeability
- Quiet close / hallway noise reduction
- Resisting: odors, mildew, mold and graffiti

## AN INVESTMENT THAT PAYS FOR ITSELF

Engineered for value-oriented customers looking to save time and avoid hassles, Scranton Products' Duralife Locker™ line provides a competitively priced option with the lowest cost of ownership when compared to metal products.

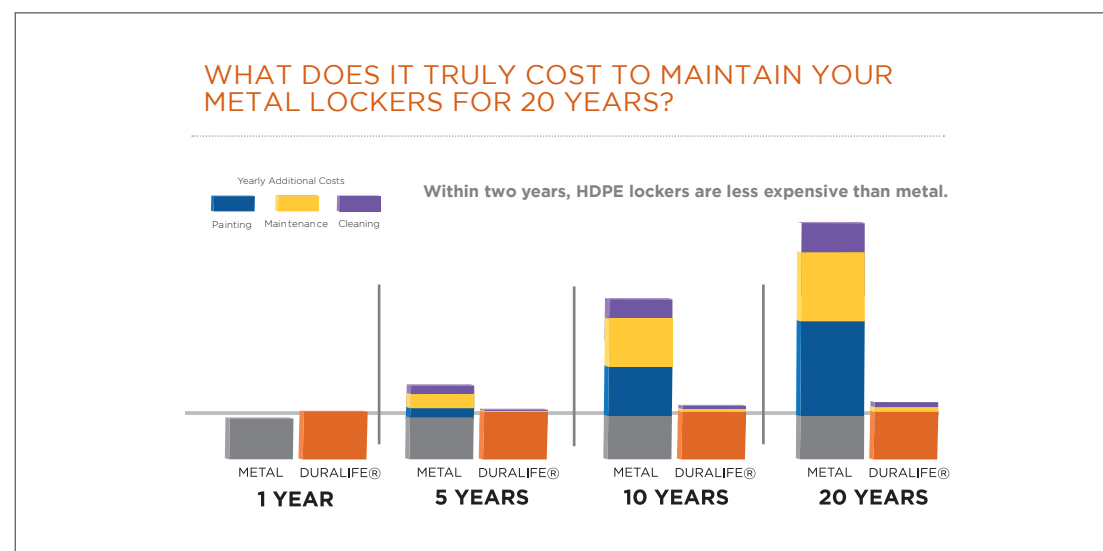

Over a 20-year period, significant savings are realized by investing in Duralife Lockers™. Compare the true cost of a metal corridor locker over a 20-year period. The above chart takes into account the initial cost, maintenance, dent and scratch repair, painting cost, graffiti removal, and replacement of damaged and corroded parts to create a cost of ownership model representing these costs over time. Within two years, HDPE lockers are less expensive than metal. In 20 years, the accumulated savings are substantial.

BATHROOM PARTITIONS  
 LOCKERS  
 LOCKER ROOM BENCHES  
 SHOWER CUBICLES  
 DRESSING COMPARTMENTS  
 VANITIES

**WE DON'T JUST TALK TOUGH.  
 WE BACK IT UP.**

Proudly made in the USA, Scranton Products' brands provide industry-leading protection. Because Scranton Products is so confident that our solid plastic lockers will stand the test of time, they're backed with a full 15-year warranty covering breakage, corrosion and delamination under normal conditions.

Call 800.445.5148 for the Scranton Products sales representative in your area, or visit [scrantonproducts.com](http://scrantonproducts.com)



Scranton Products  
 801 E. Corey Street  
 Scranton, PA 18505  
 800.445.5148  
 Fax: 800.551.6993  
 info@scrantonproducts.com  
 www.scrantonproducts.com







# BUILT FOR THE LONG HALL

## WORRY-FREE MAINTENANCE







- Graffiti readily wipes off the non-porous surface
- Sticker or contact paper easily removed
- Highly dent and impact resistant
- Solid HDPE resists odors, mold and mildew
- Fully power washable and steam cleanable
- Solid color throughout makes scratches difficult to see

## BUILT TO LAST

### STANDARD OFFERINGS

VENTING	SHELF	TIERS	HINGE	DIMENSIONS	COAT HOOK
Arc venting for improved styling 	Plastic shelf located 12" from the top (standard with 1 tier locker)	1, 2, 3* <small>*3 tier lockers can only be purchased in 72"</small>	Silver anodized steel continuous hinge 	Width 12", 15" Depth 12", 15", 18" Height 48", 60", 72"	Metal 'J' Hook 

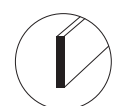
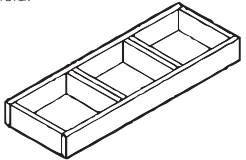
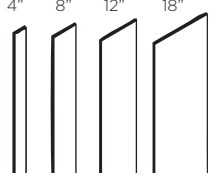
### OPTIONAL OFFERINGS

LOCKS	TOPS & TRIM	LOCKER BASE	FILLERS	HOOK
Hasp  #1 Inset Combo 	Slope  Flat 	Trim  4"-high black base, 1" thick. Bases are assembled in the field. 	4" 8" 12" 18" 72" height 	Double-Prong Black Coat Hook 

## COLOR COLLECTION

We believe our lockers' one-of-a-kind toughness should match your one-of-a-kind school. Choose from any of these popular designer colors to complement virtually any style or décor.



**CUSTOM COLORS AVAILABLE UPON REQUEST.**  
Color matching is limited by printing process. Actual samples are available and recommended prior to color selections.  
\*Special orders require extended lead times. Minimum order requirements may apply.