

COLUMBIA LOCKERS[®]

A Division of PSiSC[®]

866.337.7286
www.psisc.com



LOCKER CATALOG

NEW Recessed Handles for Phenolic Lockers
See Page 27 for More Information



ABOUT COLUMBIA LOCKERS



PSiSC is proud to provide our customers and distributors with the highest quality products made from the most durable and eco-friendly materials on the market.

Columbia Lockers, a division of PSiSC, has been manufacturing Phenolic and PolyLife® HDPE Lockers for over 15 years. Our lockers feature mortise & tenon joints, type 304 stainless steel fasteners & hardware, aluminum & stainless steel hinges, and frameless doors.

The Uni-Box® design allows for our lockers to be arranged into hundreds of configurations and can be mixed and matched to create a truly custom locker facility.

Columbia Lockers can be combined with matching benches, hardware and a variety of optional accessories.



CONTENTS

- 4 *Locker Materials*
- 8 *Locker Configurations*
- 12 *Athletic Lockers*
- 16 *Additional Options*
- 20 *Lock Options*

Innovative Design & Engineering

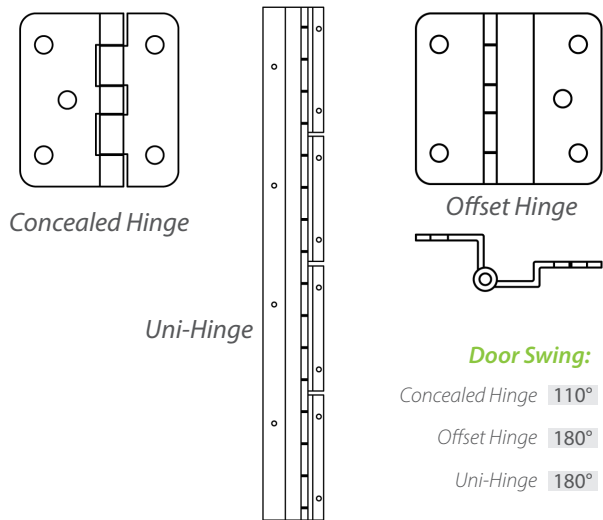

Hinges & Door Swing

Most locker designs have a limited opening and door swing, which can inhibit the end user's access to the interior of the locker. Columbia Lockers are designed with 3 additional inches of locker opening space.

Our hinges include the: **Concealed Hinge** for phenolic lockers, made from stainless steel, the **Offset Hinge** for phenolic lockers, made from powder coated stainless steel, and the **Uni-Hinge** for both phenolic lockers (*only available in black*) and PolyLife lockers (*color matched to locker*), made from powder coated aluminum.

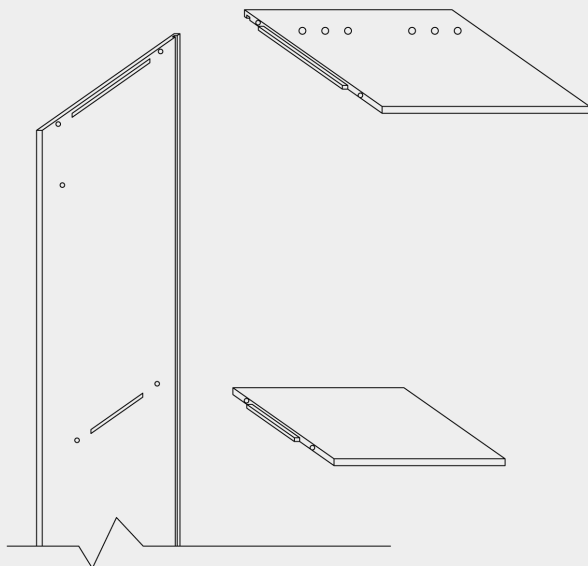

Mortise & Tenon Joints

Most lockers utilize what is known as a "butt joint," which places the majority of the weight of the locker and its contents solely on the screws. Over time, or with enough weight, the screws will bend, break, or pull away from the material, compromising the strength of the locker.

Columbia Lockers designed a virtually unbreakable joint, which is comprised of a mortise, or groove, cut in the side panel of the locker and a corresponding tenon, or projecting tab. The top, bottom, and shelves of the locker reside inside part of the side panels and are secured by stainless steel screws.

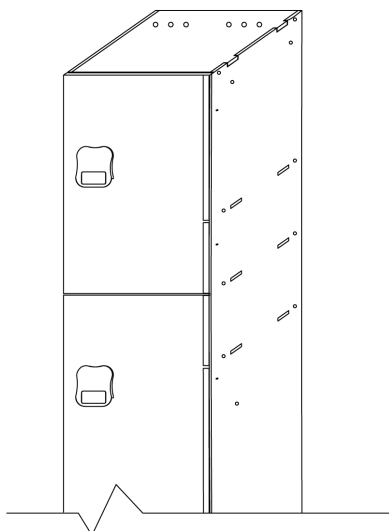

Frameless Doors & Improved Ventilation

Columbia Lockers incorporate an innovative solution to locker ventilation without unsightly louvers on the face of the locker. Our lockers are designed with an 1/8" opening between the door and the frame of the locker, along with concealed ventilation holes in the tops, bottoms, and shelves of the body.

This creative solution increases the airflow through the locker in a well-ventilated room by 3 to 4 times a standard locker with louvers.



LOCKER MATERIALS

It's time to raise the bar on our expectations of what a truly high quality locker should look like. Columbia Lockers began by selecting only the most durable, aesthetically pleasing materials on the market: Solid Phenolic and PolyLife HDPE.

These solid plastics are not only more durable, but will never rust, dent, or bend (unlike traditional metal lockers.) Take a look at each of our durable materials and the properties that set them above and beyond the rest.

LOCKER MATERIALS



POLYLIFE® (HDPE)

Also known as HDPE (High Density Polyethylene), PolyLife is created from 100% recyclable solid plastic material. It is an excellent choice for high-traffic, high-moisture areas and is resistant to damage from graffiti. PolyLife is non-porous and the same color throughout the entire material.

SPECIAL PROPERTIES:

Contributes to Green Building Certifications • Non-Porous • 25 Year Warranty • Graffiti & Wear Resistant • Never Delaminates or Requires Painting • Antimicrobial Handles

Antimicrobial PolyLife®

Protected by Columbia Guard, a microbiocidal that kills harmful bacteria on contact. The antimicrobial protection is infused throughout the material, making these lockers safer and more secure. Antimicrobial Lockers defend against MRSA, staph, and other harmful bacteria.

SPECIAL PROPERTIES:

Microbiocidal • 99.99% Kill Effectiveness on Contact • JIS Z 2801 Test Result of > 4.0 Efficacy • Contributes to LEED Certification • Can Be Cleaned Using Strong Chemicals





PHENOLIC

A high density material made by applying heat and pressure to layers of kraft paper that has been saturated in a synthetic phenolic resin. A chemical reaction known as polymerization occurs, transforming the materials into a high-pressure, thermosetting plastic. Phenolic is water resistant and highly durable, making it an excellent choice for high traffic areas.

SPECIAL PROPERTIES:

Contributes to Green Building Certifications • Multiple Thicknesses for Different Applications • Fire Rated Material Options • 20 Year Warranty • Graffiti & Wear Resistant • Never Delaminates or Requires Painting • Engravings available



TERRA CORE®

A true color-through phenolic, Columbia Terra Core features all of the same properties as standard black core phenolic, with the added aesthetic quality of a single color material. This sought-after material option adds a unique touch to any locker room design.

SPECIAL PROPERTIES:

Contributes to Green Building Certifications • Fire Rated Material Options • 25 Year Warranty • Graffiti & Wear Resistant • Never Delaminates or Requires Painting



202-2260

2137-2201 →

2200

2198

2196

2191

2188

2185

2192

2195

2190

2187

2193

2189

2197

2199

2194

2201



CONFIGURATIONS

During the design process of a locker room, it's vital to keep in mind the use and functionality of the space. We understand that no two designs are ever the same, which is why we designed our lockers to be individual units.

This modular design allows for you to have the flexibility and variety to fit any layout. The designer has the ability to maximize the amount of openings while leaving room for traffic flow within the locker room.

Being able to mix and match locker door units and configurations also allows for the possibility of mixing and matching different combinations of colors, by individual unit or by row.

We pride ourselves on manufacturing the most versatile lockers on the market. If you have a custom project or something a little "different" in mind, our team of experts can accommodate you and help design the perfect lockers for your project.

Our modular design and extensive selection of custom options can help you create nearly any style of locker room. Incorporate any combination of tiers, colors, openings, door sizes, and more - within a single locker configuration.



CONFIGURATIONS



1-6 & Z-Tier Lockers

Sizes:

Height	36" 48" 60" 72"
Width	9" 12" 15" 18"
Depth	12" 15" 18"

Material Thicknesses:

	Phenolic	PolyLife
Top, Bottom, & Shelves	3/8"	3/8"
Sides & Back	5/16"	3/8"
Doors	1/2"	1/2"
Benches	3/4"	1"

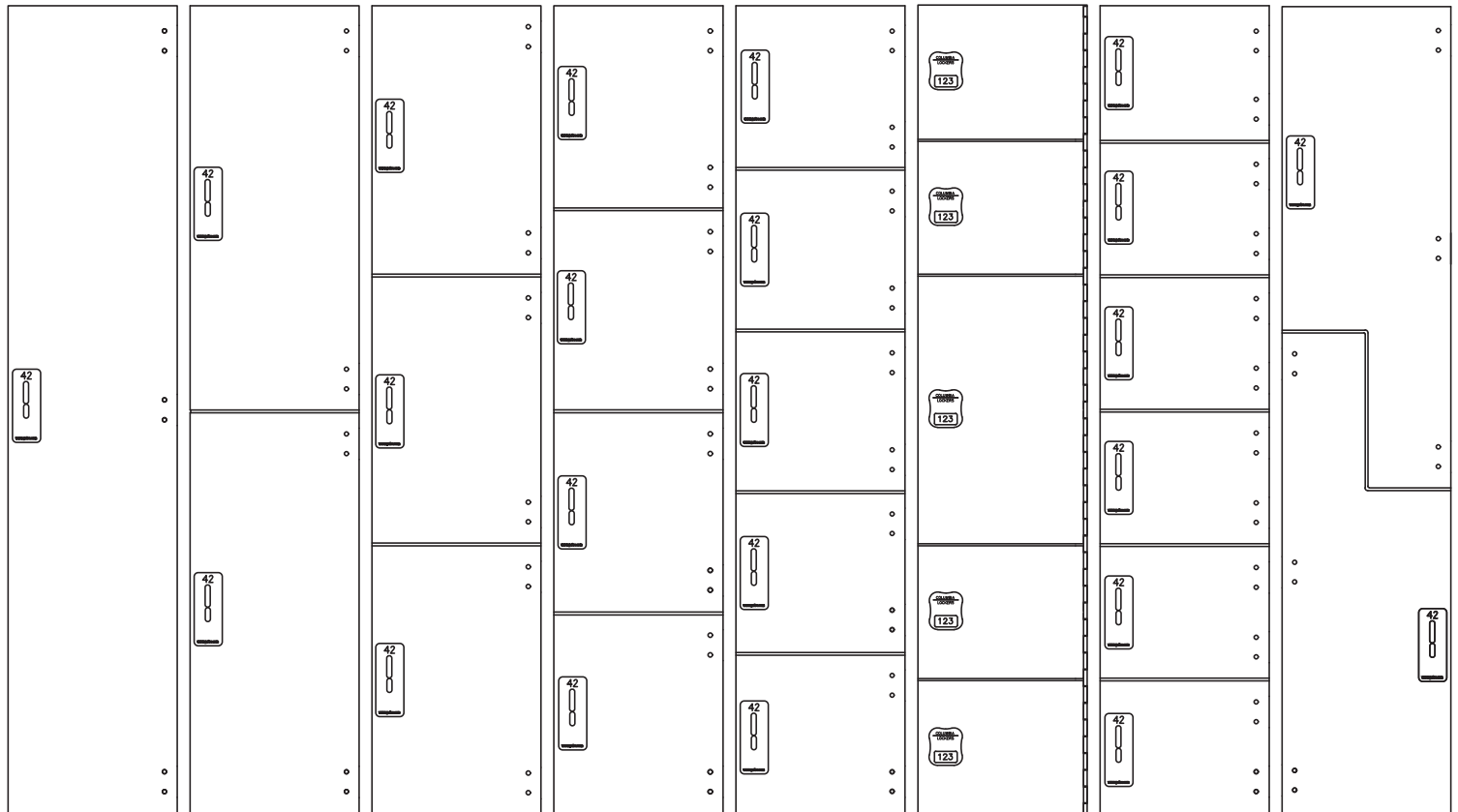

1 Tier

2 Tier

3 Tier

4 Tier

5 Tier
Phenolic

5 Tier
PolyLife

6 Tier

Z Tier

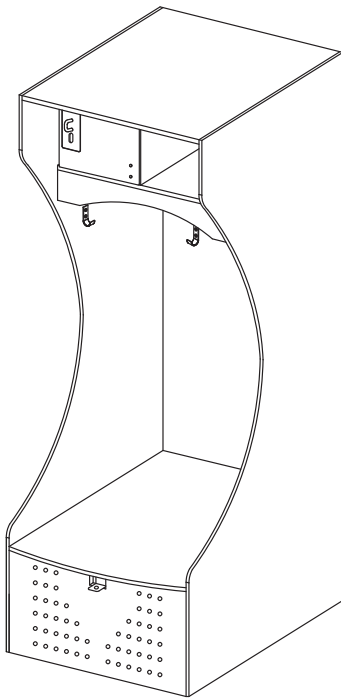

Elliptical

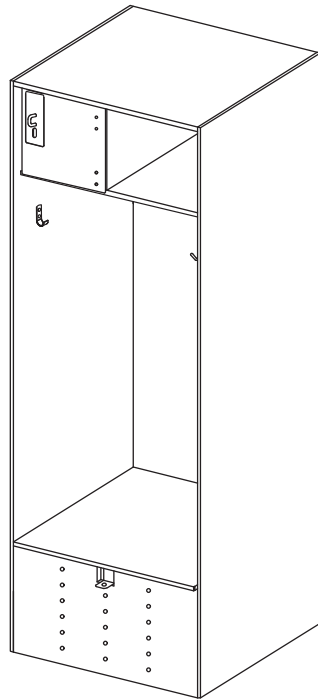

Classic

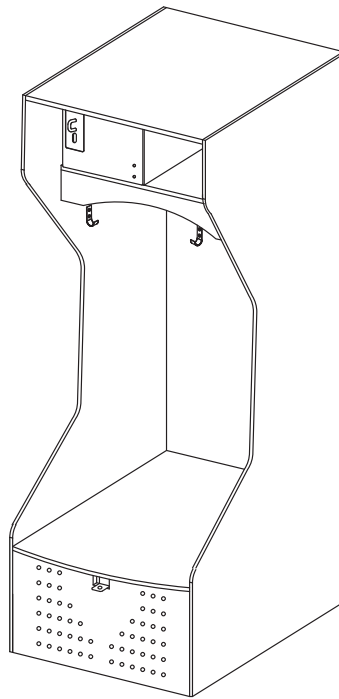

Angular

Athletic Lockers

For more information, see pg. 15

Sizes:

Height 72"

Width 18" 24" 30"

Depth 18" 24" 30"

Material Thicknesses:

Top, Bottom, & Shelves

Phenolic	PolyLife
3/8"	1/2"

Sides & Back

5/16"	1/2"
-------	------

Doors

1/2"	1/2"
------	------

Locker Seat

1/2"	1/2"
------	------

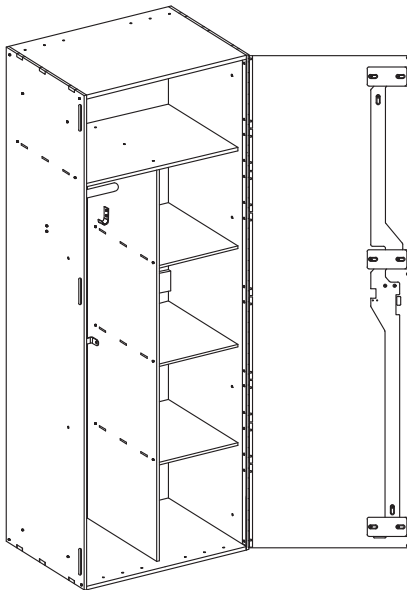

Coach's/ Executive

Sizes:

Height 72"

Width 18" 24"

Depth 18" 21" 24"

Material Thicknesses:

Top, Bottom, & Shelves

Phenolic	PolyLife
3/8"	1/2"

Sides & Back

5/16"	1/2"
-------	------

Doors

1/2"	1/2"
------	------

Benches

3/4"	1"
------	----

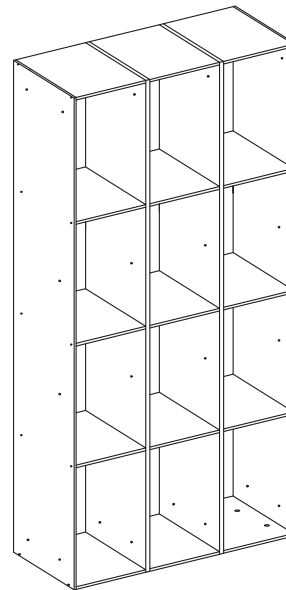

Cubbies

Sizes:

Overall Height 36" 48" 60" 72"

Overall Width 9" 12" 15" 18"

Overall Depth 12" 15" 18"

Units From 2x1 to 6x6*

*Height Dependent

Material Thicknesses:

Top, Bottom, & Shelves

Phenolic	PolyLife
3/8"	1/2"

Sides & Back

5/16"	1/2"
-------	------

Benches

3/4"	1"
------	----



ROCKETS
COLUMBIA



PSISG
1 2 3
4 5 6
7 8 9
0 ON
NVT

ATHLETIC LOCKERS

Looking for a unique storage solution that can be tailored to serve all of your team's unique needs? Columbia Lockers is proud to offer athletic lockers - choose from a full line of custom locker options, accessories, and styles that can be specialized to fit every athlete's needs, no matter what level of play.

Select one of our many standard top of the line athletic lockers:

- *Collegiate Modular Athletic Lockers*
- *High School Athletic Lockers*

or let us customize a design that is unique to you.

COLLEGIATE MODULAR ATHLETIC LOCKERS

This top of the line series features lockers best suited for professional and collegiate sports teams. Designed as a mix-and-match modular locker, you're able to choose from 4 upper sections, 6 middle sections, and 4 base sections to create up to 96 different locker combinations.

We offer a wide variety of locker accessories and options:

Glass & Acrylic Doors

LED & Custom Backlit Nameplates

Helmet & Shoulder Pad Holders

Hooks & Rod for Hanging Storage

Personal Locker with Outlets & USB for Charging Securely

Additional drawers or closures

Vented Back Plate

Custom Embroidered Bench Seats

Drawer with Shoe Compartment Dividers

Stainless Steel Storage Options



Upper Section: 4 Modules

Middle Section: 6 Modules

Base Section: 4 Modules

HIGH SCHOOL ATHLETIC LOCKERS

The high school athletic locker series features three locker body designs with a secure top locker and bottom lifting cabinet. Get all of the benefits from phenolic or PolyLife HDPE materials and add a more personal touch by mixing and matching dozens of add-ons and accessories.

We offer a wide variety of locker accessories and options:

Helmet & Shoulder Pad Holder

Choose a Lock Option for the Top Locker

Concealed Game Day Hook

Stainless Steel Hardware & Fasteners

Option for Engravings & Name Plates

Lifting Cabinet for Additional Storage

Optional Stainless Steel Top Locker & Bottom Cabinet

Choose a Material & Body Style:

Classic

Angular

Elliptical

Phenolic



PolyLife





80

81

83

82

84

ADDITIONAL OPTIONS

When it comes to designing the perfect locker room, having a wide range of accessories and locker options is imperative. Whether you're looking to add LED lighting to a locker interior, or just need benches made of the same material as the lockers, we've got you covered.

As the industry's most experienced manufacturer of phenolic and PolyLife HDPE lockers, we welcome the opportunity to create a custom locker that exceeds all expectations in both quality and design.

ADDITIONAL OPTIONS

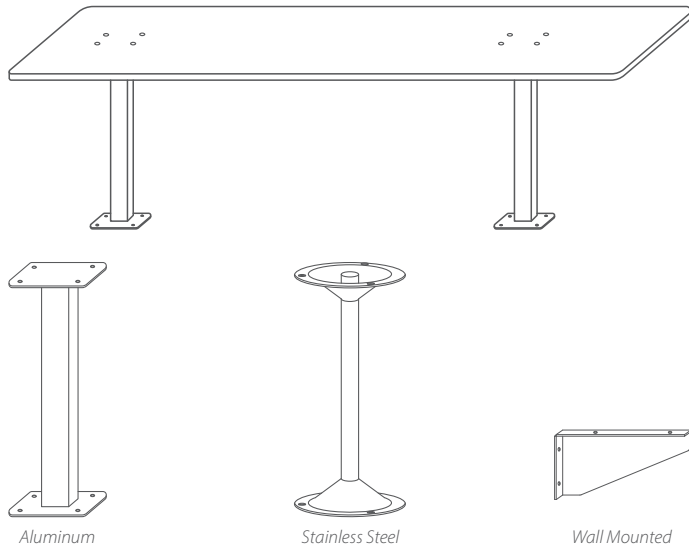

Locker Benches

Add phenolic or PolyLife HDPE locker benches to match your Columbia Lockers. Made from 1" PolyLife or 3/4" Phenolic thicknesses with rounded corners and eased edges. Bench tops are secured using thru-bolting or drilled & tapped holes for concealed attachment. Pedestals are connected to the wall or floor with stainless steel fasteners.

Choose between wall mounted (powder coated aluminum) or pedestal benches (powder coated aluminum, stainless steel, powder coated steel). ADA compliant benches are also available.

Sizes:

Length	36"	48"	60"	72"	84"	96"	120"
Depth	9"	10"	12"	24"			

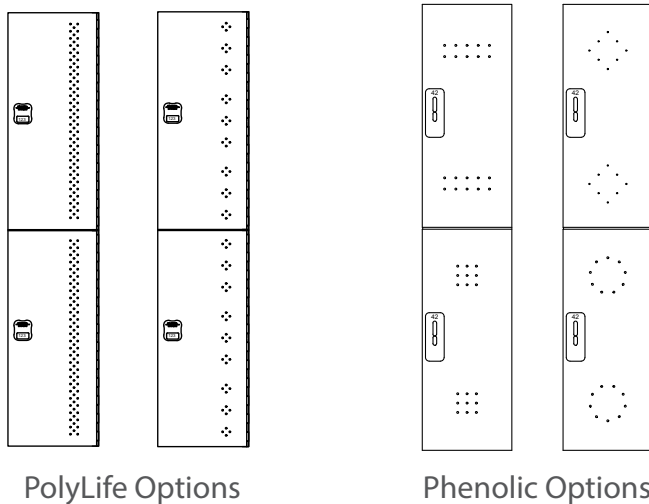

Additional Ventilation

Columbia Lockers understand that customers may desire additional ventilation. We now offer two sets of hole patterns for each of our materials that increases airflow by approximately 17% or 47%. The 1/4" diameter holes are arranged in patterns that are designed to maintain the structural integrity of the locker door.



Engravings & Logos

Looking for a more personalized locker? Add any logo or graphic to your next phenolic locker project. Get all of the durability of solid phenolic with the added aesthetic appeal of a well-designed locker surface. Our design team will convert a mascot, logo, or custom graphic into an etched pattern. Choose any color of our phenolic materials with solid black core.



Custom Designs & Solutions

When it comes to creating the perfect locker, we believe that if you can dream it, we can design & build it. From wiring electronic components to creating custom drawers and cabinets, we have every option to create the perfect locker for your team or organization.



03

05

07

09

10

11

06

08

www.PEBC.com

LOCK OPTIONS

Standard Lock Option: *Hasp Bar for Padlock*

The hasp bar for padlock is a highly versatile locking system. It allows the user to bring their own lock to secure their personal belongings. The interior hasp bar is made of 11 gauge 304 grade stainless steel. This hasp bar fits through a slot on the door, offering superior theft resistance.

The identification plate is supplied for each door and is reverse engraved on the back so the front shows the numbers and will not collect dirt. Up to 4 alphanumeric characters are allowed on each plate.



PolyLife Hasp

An antimicrobial lift-handle is connected to the door to operate the latch and activation bars. A second hasp is connected to the handle which lines up with the interior hasp bar when in the closed position. A standard padlock can then be looped through both hasp bars to secure the locker.

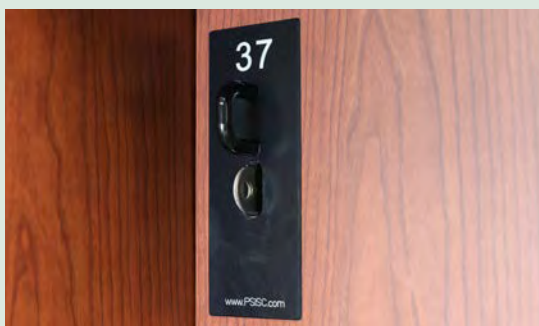

Phenolic Hasp

The hasp bar is located in the interior of the locker and fits through a slot on the face of the door, which allows any padlock to be locked on the locker. The nylon or stainless steel handle fits nicely with the engraved name plate & makes identifying and opening the locker door easy.



Phenolic Recessed Handles

Handle and lock are flush with the locker face, perfect for hallways & other areas with a lot of foot traffic.

For more info, see pg. 27

LOCK OPTIONS

MECHANICAL LOCKS



Brand	MasterLock	MasterLock	MasterLock
Model Number	1652	1670	1690
Latch Style	Springbolt	Deadbolt	Wrap Around
Locker Material	Phenolic	PolyLife	Phenolic
User Access	3-digit Combination	3-digit Combination	3-digit Combination
Supervisor Access	Lock Operation & Combo Changes	Lock Operation & Combo Changes	Lock Operation & Combo Changes
Assigned/Shared	Assigned	Assigned	Assigned
Left/Right Handed	Left/Right Handed	Left/Right Handed	Right Handed
Lock Orientations	Vertical	Vertical	Vertical
ADA Compliancy	ADA Compliant Key	ADA Compliant Key	ADA Compliant Key
Other Features	• Preloaded with 5 Combinations	• Preloaded with 5 Combinations	• Preloaded with 5 Combinations



MasterLock	Ojmar	Zephyr	Kenstan	Zephyr
3670	8001	6510	KL-100	5554
Deadbolt	Rotating Cam	Rotating Cam	Springbolt or Deadbolt	Springbolt or Deadbolt
Phenolic or PolyLife	Phenolic	Phenolic	Phenolic or PolyLife	Phenolic or PolyLife
3-digit Combination	4-digit Combination or Key	User-defined Combination (Clears Upon Opening)	Key	User-defined Combination (Clears Upon Opening)
Lock Operation & Combo Changes	Lock Operation & Combo Changes	Lock Operation & Combo Changes	Lock Operation	Lock Operation & Combo Changes
Shared	Assigned/Shared	Shared	Assigned	Shared
Left/Right Handed	Left/Right Handed	Left/Right Handed (Horizontal Orientation Only)	Left/Right Handed	Left/Right Handed
Vertical	Vertical	Vertical or Horizontal	Vertical	Vertical
N/A	N/A	N/A	N/A	N/A
• Retains Combination Until Reset	• Die-cast Lock body in Matte Chrome Finish	• Manual Turn Knob Operation • Zinc Die-cast Lock body	• Easy to Operate	• Zinc Die-cast Lock body

Important Note: Lock availability is subject to change, please refer to lock manufacturer's website for more information.

LOCK OPTIONS

ELECTRONIC LOCKS



Brand	MasterLock	Zephyr	Zephyr	Zephyr
Model Number	3685	2310	2154	2254
Latch Style	Deadbolt	Rotating Cam	Springbolt	Springbolt
Locker Material	Phenolic or PolyLife	Phenolic	Phenolic or PolyLife	Phenolic or PolyLife
User Access	4, 5, or 6-digit Combination or FOB	4 or 6-digit Combination	RFID Card Access	4-digit Combination or RFID Card Access
Supervisor Access	Lock Operation & Combo Changes	Lock Operation & Combo Changes	Lock Operation & Audit Trail	Lock Operation, Combo Changes, & Audit Trail
Assigned/Shared	Assigned/Shared	Assigned/Shared	Assigned/Shared	Assigned/Shared
Left/Right Handed	Right Handed	Right Handed	Left/Right Handed	Left/Right Handed
Lock Orientations	Vertical	Vertical or Horizontal	Horizontal	Horizontal
ADA Compliancy	ADA Compliant Options Available	N/A	ADA Compliant	ADA Compliant
Other Features	<ul style="list-style-type: none"> • CR123A Lithium Battery w/9V battery backup • Display/Sounds provide interactive feedback 	<ul style="list-style-type: none"> • 2 AA Batteries • Surface or Recessed Mounting • Master Key Override • Rubberized knob for better grip 	<ul style="list-style-type: none"> • 4 AA batteries (External battery powered emergency access) • Audible low power warning • RFID Cards, mini cards, key FOBS & wristbands 	<ul style="list-style-type: none"> • 4 AA batteries (External battery powered emergency access) • Audible low power warning • RFID Cards, mini cards, key FOBS & wristbands



Zephyr	Zephyr	Zephyr	Ojmar	CompX
6210	5154	5254	OJ-100	Cam: REG-M-V-3 Springbolt: REG-S-L-3
Rotating Cam	Springbolt	Springbolt	Springbolt or Deadbolt	Rotating Cam or Springbolt
Phenolic	Phenolic or PolyLife	Phenolic or PolyLife	Phenolic or PolyLife	Phenolic
Programmable Push Button Combination or FOB	RFID Card, FOB, or Wristband	Programmable Combination or FOB	4, 5, or 6-digit Combination or FOB	4-8-digit Combination
Lock Operation & Combo Changes	Lock Operation & Audit Trail	Lock Operation, Combo Changes, & Audit Trail	Lock Operation, Combo Changes, & Audit Trail	Lock Operation & Combo Changes
Assigned/Shared	Assigned/Shared	Assigned/Shared	Assigned/Shared	Assigned/Shared Use* <i>Cam for Assigned Use Only</i>
Left/Right Handed (Horizontal Orientation Only)	Left/Right Handed	Left/Right Handed	Left/Right Handed	Left/Right Handed
Vertical or Horizontal	Horizontal	Horizontal	Vertical	Vertical or Horizontal
ADA Compliant Options Available	ADA Compliant	ADA Compliant	ADA Compliant Options Available	N/A
<ul style="list-style-type: none"> • Zinc Die-Cast Lock Body • Wireless Capability with optional Hardwire Capability • Audible and LED visual indicators 	<ul style="list-style-type: none"> • Zinc Die-Cast Lock Body • Audible and Visual LED Indicators • Humidity Resistant 	<ul style="list-style-type: none"> • Zinc Die-Cast Lock Body • Audible and Visual LED Indicators • Humidity Resistant 	<ul style="list-style-type: none"> • Black or White Finishes • 3 Color LED for Lock Status • Automatic Open & Time-Delay Open via Software • Low Battery Indicator 	<ul style="list-style-type: none"> • Low Battery Indicator • Easy to Clean • 2 AAA Batteries (Accessible from outside of Locker Body)

Important Note: Lock availability is subject to change, please refer to lock manufacturer's website for more information.

LOCK OPTIONS

ELECTRONIC LOCKS, *Continued*



Brand	Digilock Axis	Digilock Cue	Digilock Sola	Digilock Legacy
Model Number	DL-100	DL-535	DL-540	DL-500
Latch Style	Springbolt or Deadbolt	Springbolt or Deadbolt	Rotating Cam	Springbolt or Deadbolt
Locker Material	Phenolic or PolyLife	Phenolic or PolyLife	Phenolic	Phenolic or PolyLife
User Access	4-digit Combination, Key, or Touch RFID	4-digit Combination, Key, or Touch RFID	Programmable Combination	Programmable Combination
Supervisor Access	Lock Operation & Combo Changes	Lock Operation & Combo Changes	Lock Operation & Combo Changes	Lock Operation & Combo Changes
Assigned/Shared	Assigned/Shared	Assigned/Shared	Assigned/Shared	Assigned/Shared
Left/Right Handed	Left/Right Handed	Left/Right Handed	Left/Right Handed	Left/Right Handed
Lock Orientations	Vertical or Horizontal	Vertical	Vertical or Horizontal	Vertical or Horizontal
ADA Compliancy	ADA Compliant Options Available	ADA Compliant Options Available	ADA Compliant Options Available	ADA Compliant Options Available
Other Features	<ul style="list-style-type: none"> • 4 AA batteries • 2 Models: Standard Keypad or Touch RFID Access • Optional Pull Handle • 2 Body Style Options 	<ul style="list-style-type: none"> • 4 AA batteries • 2 Models: Standard Keypad or Touch RFID Access • Integrated Pull Handle • Key or Code Managed Options 	<ul style="list-style-type: none"> • 2 AAA batteries • Visual & Audible Indicators • Key or Code Managed Operations 	<ul style="list-style-type: none"> • 4 AA batteries • Optional Pull Handle • 2 Body Style Options

Important Note: Lock availability is subject to change, please refer to lock manufacturer's website for more information.

Don't see a lock you're looking for? Ask a member of our team about a specific lock brand or model for your locker projects.

NEW

PHENOLIC RECESSED HANDLES



Solid phenolic is the most durable material for the manufacturing of lockers and is an excellent choice for high-traffic facilities. As a highly versatile and customizable material, it was a surprise to discover an important aspect was missing from the phenolic locker market: a flat locker face.

As the first and only recessed handle on the phenolic locker market, Columbia Lockers is proud to introduce this innovative design option to our entire phenolic locker product line.

Recessed handles are a safer option because passerby foot traffic can avoid bumping into or catching on a handle or lock that protrudes from the surface of the lockers.

Recessed Handles are available for any configuration of phenolic Columbia Lockers.

MANUFACTURED BY **PSiSC**®:



**COLUMBIA
LOCKERS**®

**COLUMBIA
PARTITIONS**®



**COLUMBIA
ACCESSORIES**®

SEE OUR SPECIFICATIONS:

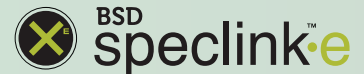

825 Garland Street | Columbia, SC 29201
www.psisc.com Office: 866.337.7286 Fax: 866.337.7291

COLUMBIA LOCKERS®, COLUMBIA PARTITIONS®, COLUMBIA ACCESSORIES®, and features are subject to one or more patent applications and these marks are trademarks of PSiSC®.

© 2018 PSiSC