

# AGF

B R O M E

## WORKBENCHES & WORKSTATIONS



**AGF BROME**

**KNOWS YOUR CHALLENGES !**

**DESIGN AND STORAGE SOLUTIONS**

147, Des Textiles St, Cowansville (Quebec) Canada J2K 3P8  
1 888 263 5993 | [WWW.AGFBROME.COM](http://WWW.AGFBROME.COM)



# WORKBENCHES & WORKSTATIONS › Housings

## > Personalizing your workbench

AGF Brome offers the possibility of personalizing your workbench in a simple way.



Following are a list of steps to help configure your ideal workbench:

1. Define the required dimensions and elements that suit your needs;
2. Select either cabinets and/or legs, which may be adjustable or not. Also require a stringer when mounting workbench with two legs;
3. Select caster option or leveling glides if required;
4. Select the under shelf and-or back and end stops if required;
5. Select the work surface material;
6. Complete your workbench by adding drawer and/or door units if such is required.

## > Housings CF17 - 28" High

CF17-182228P1



24"

CF17-182228P2



12"

12"

CF17-182228P3



6"

6"

12"

CF17-182228P4



6"

6"

12"

CF17-182228P5



6"

6"

6"

6"

CF17-182228P6



3"

3"

6"

12"

### Housing CF17 Series - 28" High

- ◆ Completely welded and made of high gauge steel;
- ◆ Available in widths of 18" and 24";
- ◆ 100% drawer opening with ball bearing mechanism;
- ◆ Drawer capacity of 120 lb. Evenly distributed;
- ◆ May be used as a stand alone cabinet or in a workstation configuration;
- ◆ Optional 2" base or 4" base with leveling glides;
- ◆ Powder coated paint AGF blue color.

### Housing - 18" wide x 28" high

22" D MODEL	28" D MODEL	DESCRIPTION	WT	
CF17-182228P1	CF17-182828P1	1 door 24"	78	87
CF17-182228P2	CF17-182828P2	2 doors 12"	79	88
CF17-182228P3	CF17-182828P3	2 drawers 6" & 1 door 12"	91	103
CF17-182228P4	CF17-182828P4	2 drawers 6" & 1 drawer 12"	105	121
CF17-182228P5	CF17-182828P5	4 drawers 6"	110	126
CF17-182228P6	CF17-182828P6	4 drawers 3" & 2 drawers 6"	112	128

### Housing - 24" wide x 28" high

22" D MODEL	28" D MODEL	DESCRIPTION	WT	
CF17-242228P1	CF17-242828P1	1 door 24"	92	103
CF17-242228P2	CF17-242828P2	2 doors 12"	97	104
CF17-242228P3	CF17-242828P3	2 drawers 6" & 1 door 12"	111	123
CF17-242228P4	CF17-242828P4	2 drawers 6" & 1 drawer 12"	127	144
CF17-242228P5	CF17-242828P5	4 drawers 6"	135	152
CF17-242228P6	CF17-242828P6	2 drawers 3", 1 drawer 6" & 1 drawer 12"	125	153

*Please contact us for a personalized solution !*

# WORBENCHES & WORKSTATIONS › Housings

## > Housings CF17 Series - 31" High

CF17-182231Q1



CF17-182231Q2

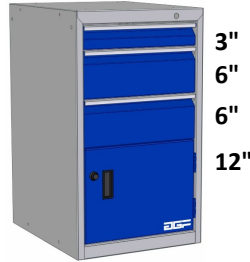

CF17-182231Q3



CF17-182231Q4



CF17-182231Q5



### Housing CF17 Series - 31" High

#### Housing - 18" wide x 31" high

22" D MODEL	28" D MODEL	DESCRIPTION	WT	
CF17-182231Q1	CF17-182831Q1	1 door 27"	83	93
CF17-182231Q2	CF17-182831Q2	1 drawer 3", 2 drawers 6" & 1 door 12"	104	118
CF17-182231Q3	CF17-182831Q3	1 drawer 3", 2 drawers 6" & 1 drawer 12"	118	136
CF17-182231Q4	CF17-182831Q4	2 drawers 3", 2 drawers 6" & 1 drawer 9"	123	141
CF17-182231Q5	CF17-182831Q5	1 drawer 3" & 4 drawers 6"	123	141

#### Housing - 24" wide x 31" high

22" D MODEL	28" D MODEL	DESCRIPTION	WT	
CF17-242231Q1	CF17-242831Q1	1 door 27"	98	107
CF17-242231Q2	CF17-242831Q2	1 drawer 3", 2 drawers 6" & 1 door 12"	125	140
CF17-242231Q3	CF17-242831Q3	1 drawer 3", 2 drawers 6" & 1 drawer 12"	140	160
CF17-242231Q4	CF17-242831Q4	2 drawers 3", 2 drawers 6" & 1 drawer 9"	148	169
CF17-242231Q5	CF17-242831Q5	1 drawer 3" & 4 drawers 6"	148	169

## > Housings CF17 - 34" High

CF17-182234R1



CF17-182234R2



CF17-182234R3



CF17-182234R4



CF17-182234R5



### Housing CF17 - 34" High

#### Housing - 18" wide x 34" high

22" D MODEL	28" D MODEL	DESCRIPTION	WT	
CF17-182234R1	CF17-182834R1	1 door 30"	88	98
CF17-182234R2	CF17-182834R2	1 drawer 6" & 1 door 24"	95	99
CF17-182234R3	CF17-182834R3	2 drawers 3", 2 drawers 6" & 1 drawer 12"	131	151
CF17-182234R4	CF17-182834R4	3 drawers 3", 2 drawers 6" & 1 drawer 9"	136	156
CF17-182234R5	CF17-182834R5	5 drawers 6"	130	149

#### Housing - 24" wide x 34" high

22" D MODEL	28" D MODEL	DESCRIPTION	WT	
CF17-242234R1	CF17-242834R1	1 door 30"	104	114
CF17-242234R2	CF17-242834R2	1 drawer 6" & 1 door 24"	107	119
CF17-242234R3	CF17-242834R3	2 drawers 3", 2 drawers 6" & 1 drawer 12"	156	179
CF17-242234R4	CF17-242834R4	3 drawers 3", 2 drawers 6" & 1 drawer 9"	164	187
CF17-242234R5	CF17-242834R5	5 drawers 6"	155	178

# WORKBENCHES & WORKSTATIONS › Legs & Options

## > Legs & options

### Legs & Options for Workbenches

AGF Brome offers different leg models to choose from. Leg assemblies are sold individually, allowing the opportunity to configure a two-legged or one leg and one cabinet workbench assembly.

#### BASE FOR HOUSING

MODEL	DESCRIPTION	WT
CF-BR1822-4	18" D x 22" D x 4" H steel rectangle base	4.4
CF-BR1828-4	18" W x 28" D x 4" H steel rectangle base	5
CF-BR2422-4	24" W x 22" D x 4" H steel rectangle base	5
CF-BR2428-4	24" W x 28" D x 4" H steel rectangle base	6

#### STANDARD LEG ASSEMBLY

MODEL	DESCRIPTION	WT
PF2028	Standard leg 20" D x 28" H	12
PF2032	Standard leg 20" D x 32" H	14
PF2026R	Standard leg 20" D x 26" H with optional casters	13
PF2728	Standard leg 27" D x 28" H	18
PF2732	Standard leg 27" D x 32" H	20
PF2726R	Standard leg 27" D x 26" H with optional casters	14

#### ADJUSTABLE LEG ASSEMBLY

MODEL	DESCRIPTION	WT
PA2024	Adjustable leg 20" D x 28" to 46" H	18
PA2024R	Adjustable leg 20" D x 24" to 46" H with optional casters	21
PA2724	Adjustable leg 27" D x 28" to 46" H	25
PA2724R	Adjustable leg 27" D x 24" to 46" H with optional casters	22

#### CASTERS

MODEL	DESCRIPTION	WT
2102	Kit of 2 5" blue Manulastic rigid casters and 2 blue Manulastic swiveling casters with brake	29

#### LEVELING GLIDES

MODEL	DESCRIPTION	WT
PN1	Pair (2) leveling glides for one leg assembly	1

#### STRINGER

MODEL	DESCRIPTION	WT
L48	42" W stringer for 48" W workbench	7
L60	54" W stringer for 60" W workbench	9
L72	66" W stringer for 72" W workbench	11

#### LOWER SHELVES

MODEL	DESCRIPTION	WT
TI4212	42" W x 12" D shelf for 48" W workbench	8
TI5412	54" W x 12" D shelf for 60" W workbench	11
TI6612	66" W x 12" D shelf for 72" W workbench	13

#### BACK STOP

MODEL	DESCRIPTION
RA4803	Painted back stop 48" W x 3" H
RA6003	Painted back stop 60" W x 3" H
RA7203	Painted back stop 72" W x 3" H

#### END STOP

MODEL	DESCRIPTION
RC2403	Painted end stop 24" D x 3" H
RC3003	Painted end stop 30" D x 3" H
RC3603	Painted end stop 36" D x 3" H



### Work surfaces for Workbenches

- ◆ A choice of 4 different work surfaces: Painted steel, laminated wood and wood-filled painted steel or stainless steel tops;
- ◆ All are 1-5/8" thick;
- ◆ Available depths of 24", 30" or 36";
- ◆ Available widths 48", 60" or 72".

	PAINTED STEEL	LAMINATED WOOD	WOOD-FILLED STEEL	WOOD-FILLED STAINLESS
48" W x 24" D	DT-AP4824	D-BL4824	DT-AB4824	DT-IB4824
48" W x 30" D	DT-AP4830	D-BL4830	DT-AB4830	DT-IB4830
48" W x 36" D	DT-AP4836	D-BL4836	DT-AB4836	DT-IB4836
60" W x 24" D	DT-AP6024	D-BL6024	DT-AB6024	DT-IB6024
60" W x 30" D	DT-AP6030	D-BL6030	DT-AB6030	DT-IB6030
60" W x 36" D	DT-AP6036	D-BL6036	DT-AB6036	DT-IB6036
72" W x 24" D	DT-AP7224	D-BL7224	DT-AB7224	DT-IB7224
72" W x 30" D	DT-AP7230	D-BL7230	DT-AB7230	DT-IB7230
72" W x 36" D	DT-AP7236	D-BL7236	DT-AB7236	DT-IB7236

## > Drawers - CT17 Series

The drawer units part of the CT17 series may be added to workstations and mounted under the worksurface for storage of documents, pen and pencils and other such items.

- ◆ All-welded high caliber steel;
- ◆ Load capacity of 120 lb. per drawer.

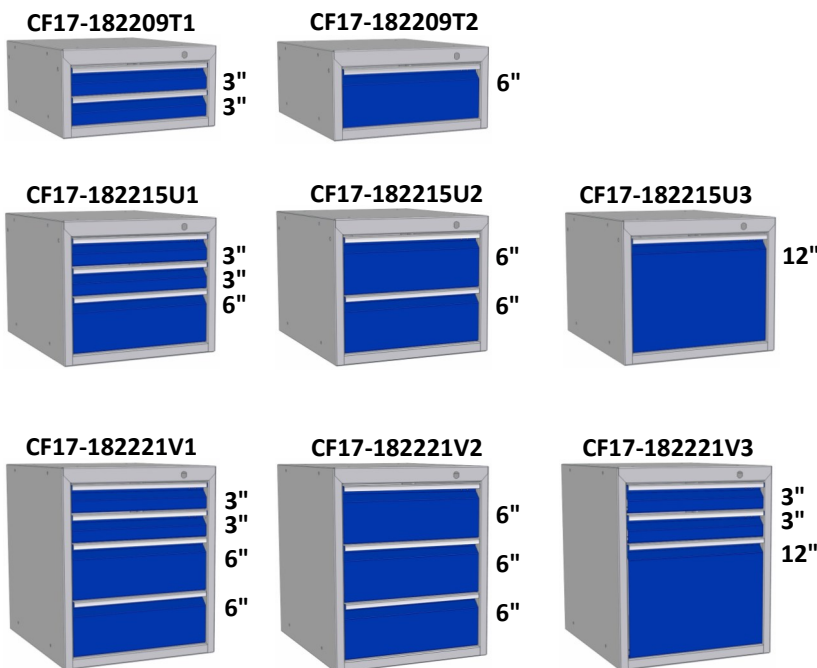

### 9" H DRAWER UNITS

	DESCRIPTION
CT17-182209T1	18" W x 22" D x 9" H - 2 Drawers 3"
CT17-182209T2	18" W x 22" D x 9" H - 1 Drawer 6"

### 15" H DRAWER UNITS

	DESCRIPTION
CT17-182215U1	18" W x 22" D x 15" H - 2 Drawers 3" & 1 drawer 6"
CT17-182215U2	18" W x 22" D x 15" H - 2 Drawers 6"
CT17-182215U3	18" W x 22" D x 15" H - 1 Drawer 12"

### 21" H DRAWER UNITS

	DESCRIPTION
CT17-182221V1	18" W x 22" D x 21" H - 2 Drawers 3" & 2 drawers 6"
CT17-182221V2	18" W x 22" D x 21" H - 3 Drawers 6"
CT17-182221V3	18" W x 22" D x 21" H - 2 Drawers 3" & 1 drawer 12"

*Please contact us for a personalized solution !*

# WORKBENCHES & WORKSTATIONS › Multi-Function

## > Personalize your workstation

The AGF Brome workstations can be personalized to fit your needs in a simple way.



Following are a list of steps to help configure your workbench.

1. Define the dimensions and required elements for your workstation;
2. Select the vertical mounting supports and horizontal structural bars;
3. Select the required back panels;
4. Make the selection of required options such as shelves, CNC tool holders, plastic bins or can holders, etc...;
5. If required, select the power supply unit;
6. Complete with the DEL lighting option.

## > RISER SHELF

Riser shelf in painted steel allows for additional storage of parts and tools.



	DESCRIPTION	WT
390-4812	Riser shelf in painted steel 48" W x 12" D x 12" H	19
390-6012	Riser shelf in painted steel 60" W x 12" D x 12" H	23
390-7212	Riser shelf in painted steel 72" W x 12" D x 12" H	26

## > VERTICAL MOUNTING POSTS

The vertical uprights support all the structural components and storage accessories that are being inserted into made to receive slots.

- ◆ Depending on the workstation dimensions, it can be configured into 1 section (using 2 posts); 2 sections (using 3 posts) or 3 sections (using 4 posts);
- ◆ These upright mounting posts are securely bolted onto the work surface;
- ◆ Available widths of 24", 30", 36" & 48";
- ◆ Available heights of 18", 24", 36" & 48".

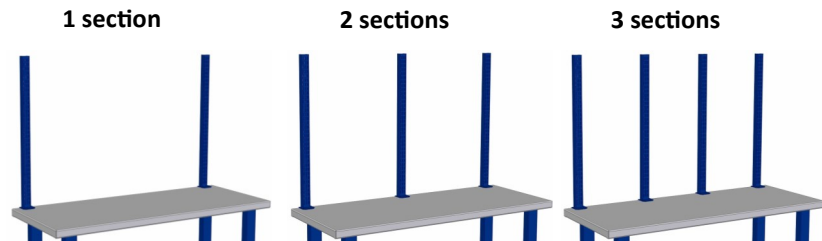

	DESCRIPTION	WT
391-MV18	Vertical mounting post 18" H	3
391-MV24	Vertical mounting post 24" H	3.5
391-MV36	Vertical mounting post 36" H	4.5
391-MV48	Vertical mounting post 48" H	5.5

*Please contact us for a personalized solution !*

# WORBENCHES & WORKSTATIONS › Multi-Function

## > Horizontal structural bars

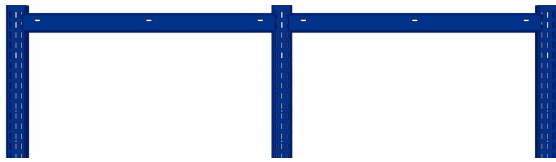

The horizontal structural bars are installed onto the vertical uprights therefore reinforcing the structure.

	DESCRIPTION	WT
392-MH24	Horizontal structural bar 24" W	1.5
392-MH30	Horizontal structural bar 30" W	2
392-MH36	Horizontal structural bar 36" W	2.25
392-MH48	Horizontal structural bar 48" W	3

## > Perforated & Louvered Back Panels

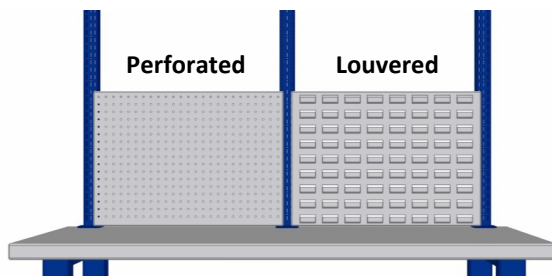

The back panels allow attachment of tool rods and/or plastic bins. There again, they are clipped onto the vertical uprights.

- ◆ Available in louvered or perforated;
- ◆ Available heights of 6", 12", 18", 24", 30" & 36";
- ◆ Available widths of 24", 30", 36" & 48".

DIMENSIONS	LOUVERED	PERFORATED
6" H x 24" W	393-PL2406	393-PP2406
6" H x 30" W	393-PL3006	393-PP3006
6" H x 36" W	393-PL3606	393-PP3606
6" H x 48" W	393-PL4806	393-PP4806
12" H x 24" W	393-PL2412	393-PP2412
12" H x 30" W	393-PL3012	393-PP3012
12" H x 36" W	393-PL3612	393-PP3612
12" H x 48" W	393-PL4812	393-PP4812
18" H x 24" W	393-PL2418	393-PP2418
18" H x 30" W	393-PL3018	393-PP3018
18" H x 36" W	393-PL3618	393-PP3618
18" H x 48" W	393-PL4818	393-PP4818

DIMENSIONS	LOUVERED	PERFORATED
24" H x 24" W	393-PL2424	393-PP2424
24" H x 30" W	393-PL3024	393-PP3024
24" H x 36" W	393-PL3624	393-PP3624
24" H x 48" W	393-PL4824	393-PP4824
36" H x 24" W	393-PL2436	393-PP2436
36" H x 30" W	393-PL3036	393-PP3036
36" H x 36" W	393-PL3636	393-PP3636
36" H x 48" W	393-PL4836	393-PP4836
48" H x 24" W	393-PL2448	393-PP2448
48" H x 30" W	393-PL3048	393-PP3048
48" H x 36" W	393-PL3648	393-PP3648
48" H x 48" W	393-PL4848	393-PP4848

## > LED Lighting Support



The LED lighting support is installed onto the structure and allows for installation of the LED unit.

	DESCRIPTION	WT
394-SL24	LED lighting support 24" W	6
394-SL30	LED lighting support 30" W	7
394-SL36	LED lighting support 36" W	7
394-SL48	LED lighting support 48" W	8

## > LED Lighting



AGF Brome offers a wide range of LED lighting systems. However, since models evolve regularly, we suggest you contact us for updated information.

# WORKBENCHES & WORKSTATIONS › Multi-Function

## > Back Stop

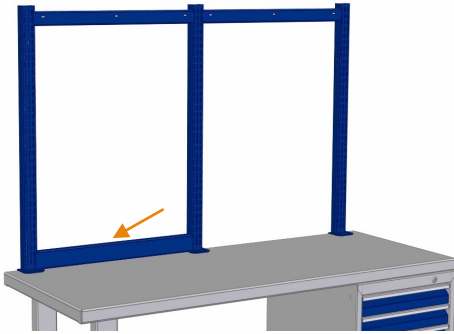

The back stop is clipped onto the vertical uprights and prevents tools and parts from falling.

- ◆ 3" high by required length;
- ◆ Lengths of 24", 30", 36" and 48".

MODEL	DESCRIPTION	WT
395-D2403	24" L x 3" H back stop	2
395-D3003	30" L x 3" H back stop	2.25
395-D3603	36" L x 3" H back stop	3
395-D4803	48" L x 3" H back stop	4

## > Adjustable Shelves

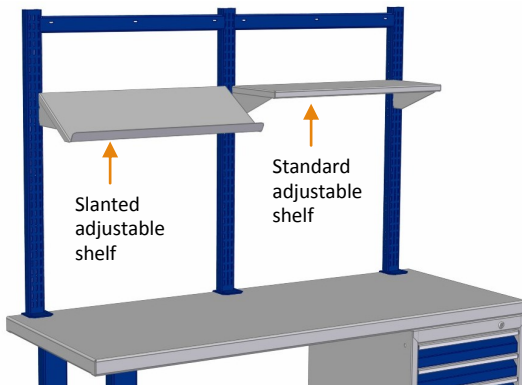

The adjustable shelves are then again clipped onto the vertical uprights. Available in a standard or slanted versions.

- ◆ Adjust with a 1" increment;
- ◆ 10" deep;
- ◆ Available lengths of 24", 30", 36" and 48";
- ◆ Load capacity of 110 lb.

### STANDARD ADJUSTABLE SHELF

MODEL	DESCRIPTION	WT
396-TD24	24" L x 10" D standard shelf	5.5
396-TD30	30" L x 10" D standard shelf	7
396-TD36	36" L x 10" D standard shelf	8
396-TD48	48" L x 10" D standard shelf	11

### SLANTED ADJUSTABLE SHELF

MODEL	DESCRIPTION	WT
396-TI24	24" L x 10" D slanted shelf	5
396-TI30	30" L x 10" D slanted shelf	6
396-TI36	36" L x 10" D slanted shelf	7.5
396-TI48	48" L x 10" D slanted shelf	10

## > Wire Spool Support

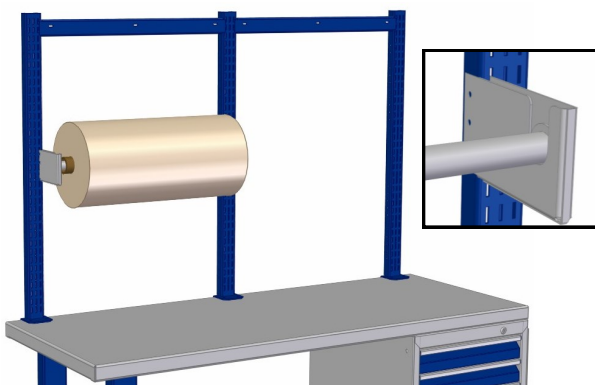

The wire spool support holds plastic film, paper and other rolls necessary in any packaging/shipping activities. It is clipped and screwed onto the vertical uprights.

- ◆ Adjusts in 1" increment;
- ◆ Comes with a 1" diameter metal rod;

MODEL	DESCRIPTION	WT
397-SR36	36" L wire spool support	4
397-SR48	48" L wire spool support	4.5

*Please contact us for a personalized solution !*



## > CNC Tool Rack Brackets

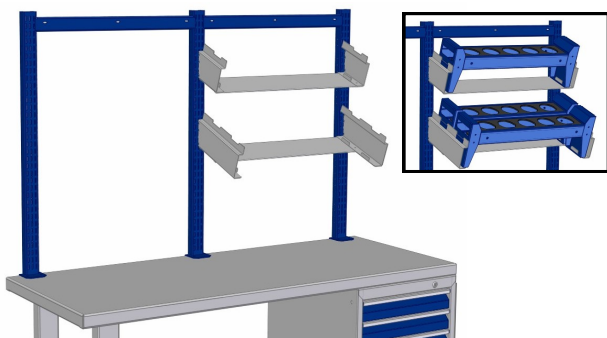

The CNC tool brackets hold the CNC tool racks and is there again clipped onto the vertical uprights.

- ◆ Adjust with a 1" increment;
- ◆ Widths of 30" and 36";
- ◆ The CNC tool racks are not included.

MODEL	DESCRIPTION	WT
398-SC30S	CNC tool support brackets 30" W for single rack	4.25
398-SC30D	CNC tool support brackets 30" W for double rack	5.50
398-SC36S	CNC tool support brackets 36" W for single rack	5
398-SC36D	CNC tool support brackets 36" W for double rack	6

## > Power Outlet Modules

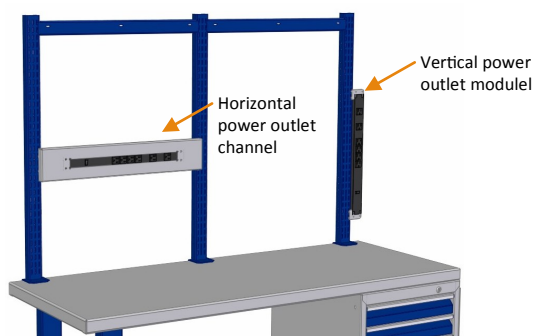

The power outlet modules are offered in two different models and are both to be clipped onto the vertical uprights.

- ◆ Available in horizontal or vertical version;
- ◆ Horizontal version available in lengths of 24", 30", 36" and 48".

### VERTICAL POWER OUTLET MODULE

MODEL	DESCRIPTION
399-PBV	Vertical power outlet module

### HORIZONTAL POWER OUTLET MODULE

MODEL	DESCRIPTION
399-PB24H	24" L horizontal power outlet module
399-PB30H	30" L horizontal power outlet module
399-PB36H	36" L horizontal power outlet module
399-PB48H	48" L horizontal power outlet module

## > Overhead Cabinets CS17



The overhead cabinets are clipped onto the vertical uprights and offered in two different models.

- ◆ Two different models are offered: With hinged or flipper doors;
- ◆ No edges on the bottom of the cabinets for 100% access of content without having to lift it;
- ◆ Optional lock.

### DOUGLE HINGED-DOOR OVERHEAD CABINETS

MODEL	DESCRIPTION	WT
CS17-241418H	24" W x 14" D x 18" H double hinged-doors	33
CS17-301418H	30" W x 14" D x 18" H double hinged-doors	40
CS17-361418H	36" W x 14" D x 18" H double hinged-doors	47
CS17-481418H	48" W x 14" D x 18" H double hinged-doors	57

### FLIPPER DOOR OVERHEAD CABINETS

MODEL	DESCRIPTION	WT
CS17-241418V	24" W x 14" D x 18" H flipper door	33
CS17-301418V	30" W x 14" D x 18" H flipper door	40
CS17-361418V	36" W x 14" D x 18" H flipper door	47
CS17-481418V	48" W x 14" D x 18" H flipper door	57

## > Preconfigured Workbenches

These preconfigured workbenches are of industrial quality, sturdy and durable. They are available in a wide range of sizes and configurations.

- ◆ Offer a 5000-lb load capacity when evenly distributed on top;
- ◆ Available widths of 48", 60" & 72";
- ◆ Available depths of 24", 30" & 36";
- ◆ Choice of four different top types, all 1-5/8" thick;
- ◆ The steel tops have a durable powder coated paint finish;
- ◆ Optional casters are available for mobility.



### Model 300 Basic Workbench - 34" H

- ◆ Multi-purpose workbench

DIMENSIONS	SURFACES			
	Painted steel	Laminated wood	Wood-filled / Painted steel	Wood-filled / Stainless S
24 x 48"	300-2448AP	300-2448BL	300-2448AB	300-2448IB
24 x 60"	300-2460AP	300-2460BL	300-2460AB	300-2460IB
30 x 60"	300-3060AP	300-3060BL	300-3060AB	300-3060IB
30 x 72"	300-3072AP	300-3072BL	300-3072AB	300-3072IB
36 x 60"	300-3660AP	300-3660BL	300-3660AB	300-3660IB
36 x 72"	300-3672AP	300-3672BL	300-3672AB	300-3672IB



### Model 301 Workbench With Lower Shelf - 34" H

- ◆ Useful lower storage shelf

DIMENSIONS	SURFACES			
	Painted steel	Laminated wood	Wood-filled / Painted steel	Wood-filled / Stainless S
24 x 48"	301-2448AP	301-2448BL	301-2448AB	301-2448IB
24 x 60"	301-2460AP	301-2460BL	301-2460AB	301-2460IB
30 x 60"	301-3060AP	301-3060BL	301-3060AB	301-3060IB
30 x 72"	301-3072AP	301-3072BL	301-3072AB	301-3072IB
36 x 60"	301-3660AP	301-3660BL	301-3660AB	301-3660IB
36 x 72"	301-3672AP	301-3672BL	301-3672AB	301-3672IB



### Model 302 Workbench With drawer & Lower Shelf - 34" H

- ◆ Useful lower storage shelf;
- ◆ One drawer 6" H (Load capacity of 120 lb).

DIMENSIONS	SURFACES			
	Painted steel	Laminated wood	Wood-filled / Painted steel	Wood-filled / Stainless S
24 x 48"	301-2448AP	301-2448BL	301-2448AB	301-2448IB
24 x 60"	301-2460AP	301-2460BL	301-2460AB	301-2460IB
30 x 60"	301-3060AP	301-3060BL	301-3060AB	301-3060IB
30 x 72"	301-3072AP	301-3072BL	301-3072AB	301-3072IB
36 x 60"	301-3660AP	301-3660BL	301-3660AB	301-3660IB
36 x 72"	301-3672AP	301-3672BL	301-3672AB	301-3672IB

*Please contact us for a personalized solution !*



### Model 310 Workbench With Leg & Cabinet - 34" H

- ◆ One standard leg on one end;
- ◆ 1 door cabinet 24" H, 18" W, with 4" H base on the other end.

DIMENSIONS	SURFACES			
	Painted steel	Laminated wood	Wood-filled / Painted steel	Wood-filled / Stainless S
24 x 48"	310-2448AP	310-2448BL	310-2448AB	310-2448IB
24 x 60"	310-2460AP	310-2460BL	310-2460AB	310-2460IB
30 x 60"	310-3060AP	310-3060BL	310-3060AB	310-3060IB
30 x 72"	310-3072AP	310-3072BL	310-3072AB	310-3072IB
36 x 60"	310-3660AP	310-3660BL	310-3660AB	310-3660IB
36 x 72"	310-3672AP	310-3672BL	310-3672AB	310-3672IB



### Model 311 Workbench With Leg & Cabinet - 34" H

- ◆ One standard leg on one end;
- ◆ 2 drawers 6" & 1 door 12" H cabinet, 18"W with 4" H base on other end.

DIMENSIONS	SURFACES			
	Painted steel	Laminated wood	Wood-filled / Painted steel	Wood-filled / Stainless S
24 x 48"	311-2448AP	311-2448BL	311-2448AB	311-2448IB
24 x 60"	311-2460AP	311-2460BL	311-2460AB	311-2460IB
30 x 60"	311-3060AP	311-3060BL	311-3060AB	311-3060IB
30 x 72"	311-3072AP	311-3072BL	311-3072AB	311-3072IB
36 x 60"	311-3660AP	311-3660BL	311-3660AB	311-3660IB
36 x 72"	311-3672AP	311-3672BL	311-3672AB	311-3672IB



### Model 312 Workbench With Leg & Cabinet - 34" H

- ◆ One standard leg on one end;
- ◆ 2 drawers 6" & 1 drawer 12" H cabinet 18" W with 4" H base on other end.

DIMENSIONS	SURFACES			
	Painted steel	Laminated wood	Wood-filled / Painted steel	Wood-filled / Stainless S
24 x 48"	312-2448AP	312-2448BL	312-2448AB	312-2448IB
24 x 60"	312-2460AP	312-2460BL	312-2460AB	312-2460IB
30 x 60"	312-3060AP	312-3060BL	312-3060AB	312-3060IB
30 x 72"	312-3072AP	312-3072BL	312-3072AB	312-3072IB
36 x 60"	312-3660AP	312-3660BL	312-3660AB	312-3660IB
36 x 72"	312-3672AP	312-3672BL	312-3672AB	312-3672IB



### Model 313 Workbench with Leg & Cabinet - 34" H

- ◆ One standard leg on one end;
- ◆ 4 drawers 6" H cabinet, 18" W, with 4" H base on other end.

DIMENSIONS	SURFACES			
	Painted steel	Laminated wood	Wood-filled / Painted steel	Wood-filled / Stainless S
24 x 48"	312-2448AP	312-2448BL	312-2448AB	312-2448IB
24 x 60"	312-2460AP	312-2460BL	312-2460AB	312-2460IB
30 x 60"	312-3060AP	312-3060BL	312-3060AB	312-3060IB
30 x 72"	312-3072AP	312-3072BL	312-3072AB	312-3072IB
36 x 60"	312-3660AP	312-3660BL	312-3660AB	312-3660IB
36 x 72"	312-3672AP	312-3672BL	312-3672AB	312-3672IB

# WORKBENCHES & WORKSTATIONS › Preconfigured

## > Preconfigured Workbenches



### Model 314 With Leg & Cabinet - 34" H

- ◆ Standard leg on one end;
- ◆ 4 drawers 3" & 2 drawers 6" H cabinet, 18" W, with 4" H base.

DIMENSIONS	SURFACES			
	Painted steel	Laminated wood	Wood-filled / Painted steel	Wood-filled / Stainless S
24 x 48"	314-2448AP	314-2448BL	314-2448AB	314-2448IB
24 x 60"	314-2460AP	314-2460BL	314-2460AB	314-2460IB
30 x 60"	314-3060AP	314-3060BL	314-3060AB	314-3060IB
30 x 72"	314-3072AP	314-3072BL	314-3072AB	314-3072IB
36 x 60"	314-3660AP	314-3660BL	314-3660AB	314-3660IB
36 x 72"	314-3672AP	314-3672BL	314-3672AB	314-3672IB



### Model 320 With 2 Cabinets 18"W - 34" H

- ◆ 1 door 24" cabinet with 4" H base on one end;
- ◆ 4 drawers 6" H cabinet with 4" H base on the other end.

DIMENSIONS	SURFACES			
	Painted steel	Laminated wood	Wood-filled / Painted steel	Wood-filled / Stainless S
24 x 48"	320-2448AP	320-2448BL	320-2448AB	320-2448IB
24 x 60"	320-2460AP	320-2460BL	320-2460AB	320-2460IB
30 x 60"	320-3060AP	320-3060BL	320-3060AB	320-3060IB
30 x 72"	320-3072AP	320-3072BL	320-3072AB	320-3072IB
36 x 60"	320-3660AP	320-3660BL	320-3660AB	320-3660IB
36 x 72"	320-3672AP	320-3672BL	320-3672AB	320-3672IB



### Model 321 With 2 Cabinets 18"W - 34" H

- ◆ 2 drawers 6" & 1 drawer 12" H cabinet with 4" H base on both ends.

DIMENSIONS	SURFACES			
	Painted steel	Laminated wood	Wood-filled / Painted steel	Wood-filled / Stainless S
24 x 48"	321-2448AP	321-2448BL	321-2448AB	321-2448IB
24 x 60"	321-2460AP	321-2460BL	321-2460AB	321-2460IB
30 x 60"	321-3060AP	321-3060BL	321-3060AB	321-3060IB
30 x 72"	321-3072AP	321-3072BL	321-3072AB	321-3072IB
36 x 60"	321-3660AP	321-3660BL	321-3660AB	321-3660IB
36 x 72"	321-3672AP	321-3672BL	321-3672AB	321-3672IB



### Model 322 With 2 Cabinets 18"W - 34" H

- ◆ 4 drawers 6" H cabinet with 4" H base on both ends.

DIMENSIONS	SURFACES			
	Painted steel	Laminated wood	Wood-filled / Painted steel	Wood-filled / Stainless S
24 x 48"	322-2448AP	322-2448BL	322-2448AB	322-2448IB
24 x 60"	322-2460AP	322-2460BL	322-2460AB	322-2460IB
30 x 60"	322-3060AP	322-3060BL	322-3060AB	322-3060IB
30 x 72"	322-3072AP	322-3072BL	322-3072AB	322-3072IB
36 x 60"	322-3660AP	322-3660BL	322-3660AB	322-3660IB
36 x 72"	322-3672AP	322-3672BL	322-3672AB	322-3672IB

*Please contact us for a personalized solution !*



### Model 323 With 2 cabinets 18"D - 34" H

- ◆ 2 drawers 3", 2 x 6" & 1 drawer 12" H cabinet with 4" H base one end;
- ◆ 4 drawers 6" H cabinet with 4" H base on the other end.

DIMENSIONS	SURFACES			
	Painted steel	Laminated wood	Wood-filled / Painted steel	Wood-filled / Stainless S
24 x 48"	323-2448AP	323-2448BL	323-2448AB	323-2448IB
24 x 60"	323-2460AP	323-2460BL	323-2460AB	323-2460IB
30 x 60"	323-3060AP	323-3060BL	323-3060AB	323-3060IB
30 x 72"	323-3072AP	323-3072BL	323-3072AB	323-3072IB
36 x 60"	323-3660AP	323-3660BL	323-3660AB	323-3660IB
36 x 72"	323-3672AP	323-3672BL	323-3672AB	323-3672IB

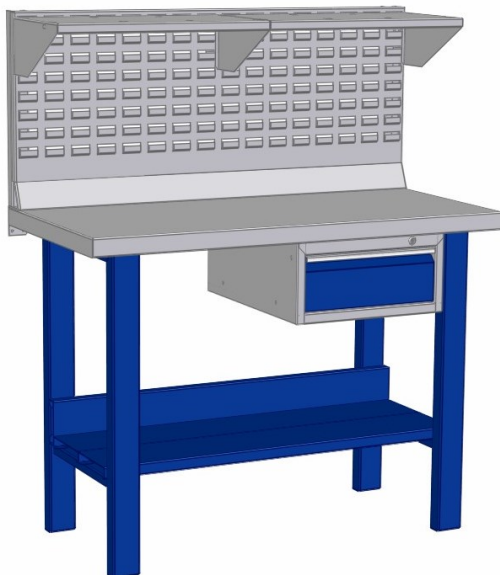

### Model 330 Workshop Bench - 34" H

- ◆ 2 standard legs on both ends;
- ◆ Useful lower storage shelf;
- ◆ One 6" H drawer unit;
- ◆ Full width louvered back panel for plastic bins, mini-shelf, glue tube and spray paint cans holders (optional)
- ◆ Clip-on upper shelf for lighting and storage.

(All shown accessories on panel and upper shelf are optional)

DIMENSIONS	SURFACES			
	Painted steel	Laminated wood	Wood-filled / Painted steel	Wood-filled / Stainless S
24 x 48"	330-2448AP	330-2448BL	330-2448AB	330-2448IB
24 x 60"	330-2460AP	330-2460BL	330-2460AB	330-2460IB
30 x 60"	330-3060AP	330-3060BL	330-3060AB	330-3060IB
30 x 72"	330-3072AP	330-3072BL	330-3072AB	330-3072IB
36 x 60"	330-3660AP	330-3660BL	330-3660AB	330-3660IB
36 x 72"	330-3672AP	330-3672BL	330-3672AB	330-3672IB

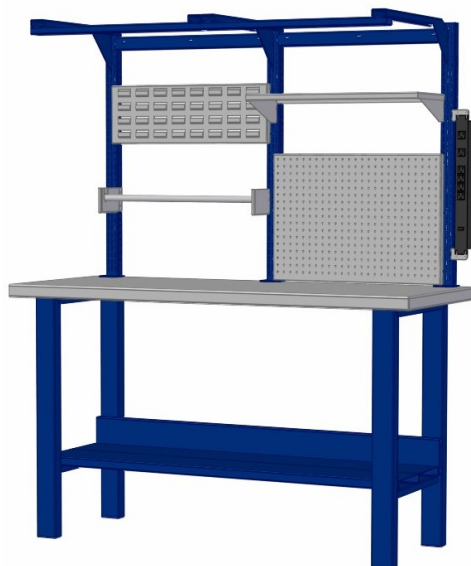

### Model 331 Warehouse Workstation - 34" H

- ◆ 2 standard legs on both end;
- ◆ Useful lower storage shelf;
- ◆ Perforated back panel for tool rods;
- ◆ Louvered back panel for plastic bins, mini-shelf, glue tube and spray paint cans holders (optional);
- ◆ Spool support;
- ◆ Power outlet strip ;
- ◆ Storage shelf;
- ◆ Horizontal structural bars for lighting and added strength.

DIMENSIONS	SURFACES			
	Painted steel	Laminated wood	Wood-filled / Painted steel	Wood-filled / Stainless S
24 x 48"	331-2448AP	331-2448BL	331-2448AB	331-2448IB
24 x 60"	331-2460AP	331-2460BL	331-2460AB	331-2460IB
30 x 60"	331-3060AP	331-3060BL	331-3060AB	331-3060IB
30 x 72"	331-3072AP	331-3072BL	331-3072AB	331-3072IB
36 x 60"	331-3660AP	331-3660BL	331-3660AB	331-3660IB
36 x 72"	331-3672AP	331-3672BL	331-3672AB	331-3672IB



B R O M E

## > Product Family



## > Choice of Colors

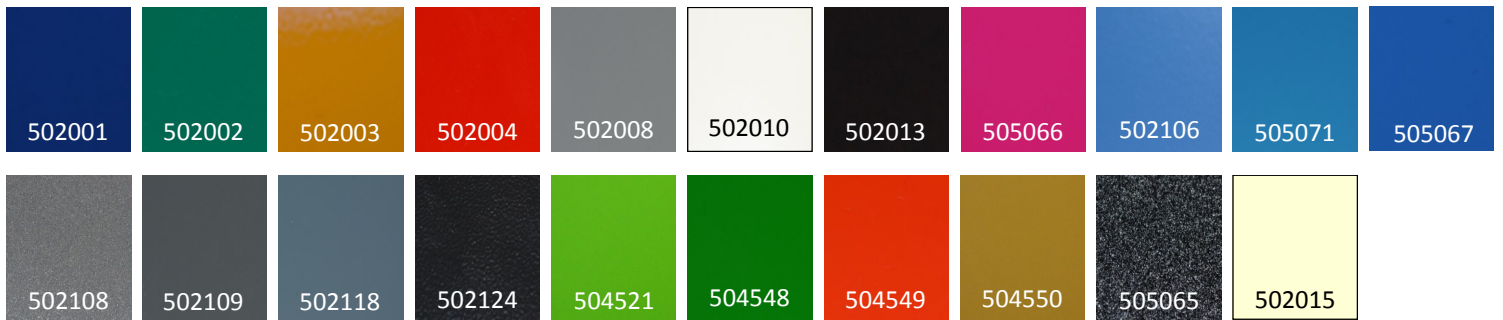

1 888 263 5993

147, Des Textiles  
Cowansville (Quebec) J2K 3P8

[WWW.AGFBROME.COM](http://WWW.AGFBROME.COM)

